

5' X 5' JUNCTION BOX W/ RISER

NOT TO SCALE: ALL DIMENSIONS ARE SUBJECT TO ALLOWABLE SPECIFICATION TOLERANCES

MATERIALS & FEATURES
 CONCRETE: 5,000 PSI, 28 DAY STRENGTH.
 REINFORCING: #4 BAR, GRADE 60, 8" O.C.E.W.
 #4 BAR DIAGONAL AROUND KNOCK-OUTS
 STOCK DEPTH: VARIES
 TOP SLAB LOAD RATING = H-20.
 EXCEEDS ASTM C858

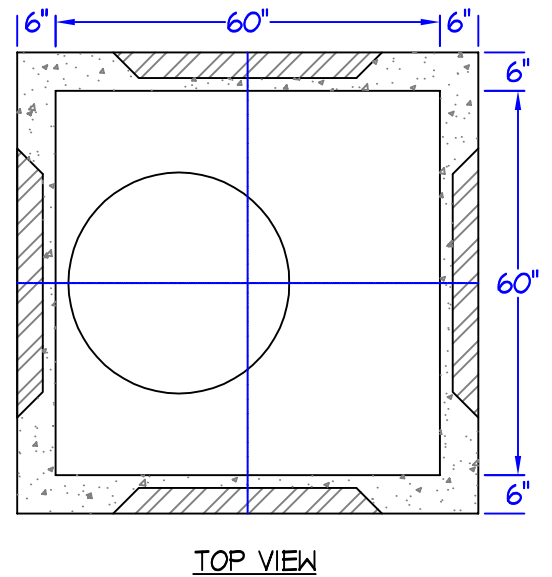
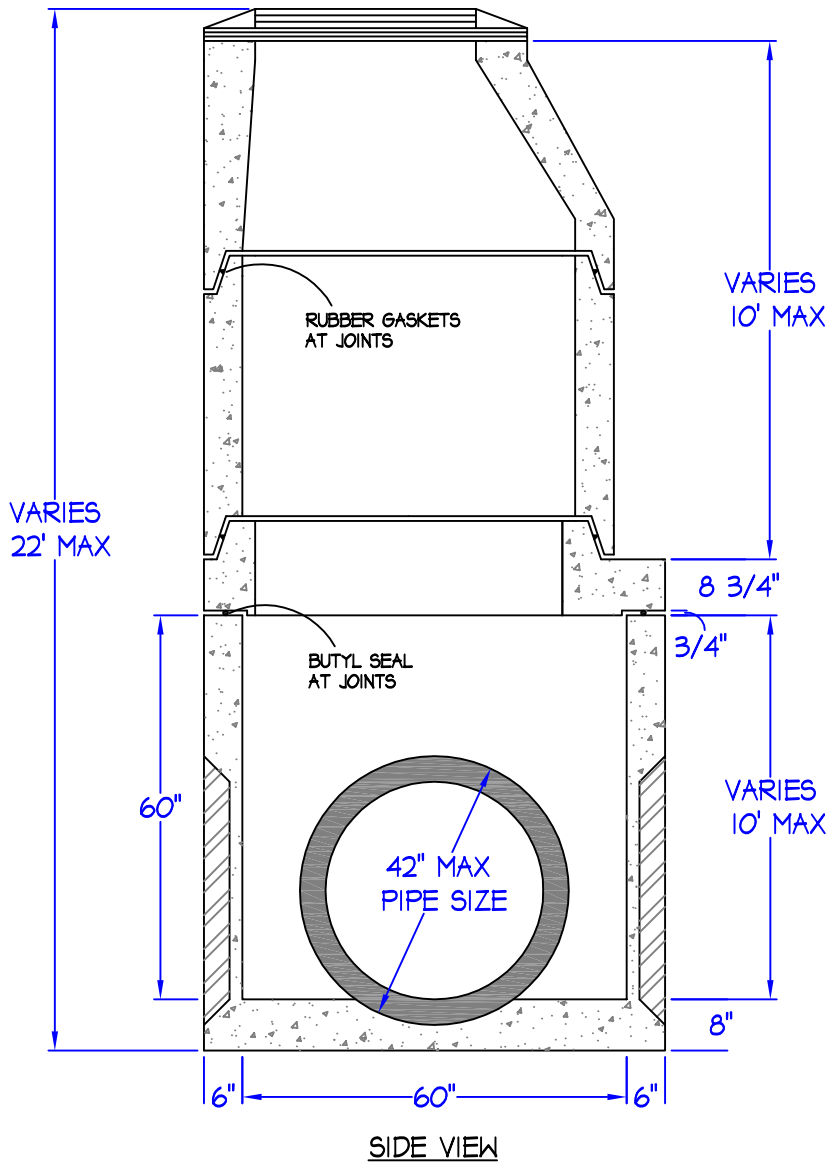

Capital Concrete Products

5264 Hwy. 71 East • Del Valle, Texas 78617

TITLE:	5' X 5' JUNCTION BOX W/ RISER
FILE NAME:	JUNCTION BOX/5 X 5 WR.DWG
DRAWN BY:	SUSAN MENTA
DATE:	SEPTEMBER 03, 2009