

# 5' X 5' JUNCTION BOX

NOT TO SCALE: ALL DIMENSIONS ARE SUBJECT TO ALLOWABLE SPECIFICATION TOLERANCES

**MATERIALS & FEATURES**

CONCRETE: 5,000 PSI, 28 DAY STRENGTH.  
 REINFORCING: #4 BAR, GRADE 60, 8" O.C.E.W.  
 #4 BAR DIAGONAL AROUND KNOCK-OUTS  
 2 MATS #4 BAR 8" O.C.E.W. IN LID W/  
 DIAGONAL AROUND HOLE  
 STOCK DEPTH: 60"  
 TOP SLAB LOAD RATING = H-20.  
 EXCEEDS ASTM C858

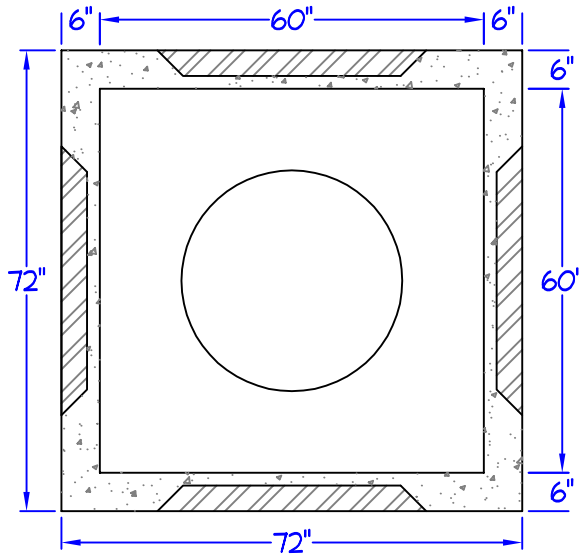

TOP VIEW

CAST IRON MANHOLE RING AND COVER AS REQUIRED (FLUSH MOUNT AVAILABLE)

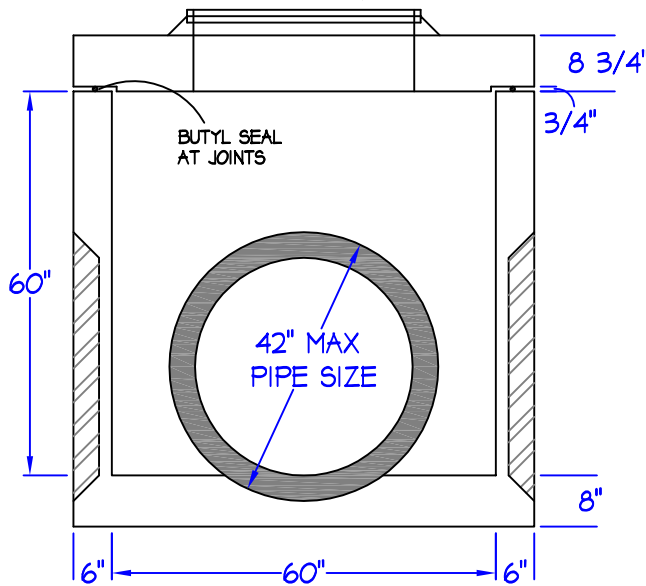

SIDE VIEW



**Capital Concrete Products**

5264 Hwy. 71 East • Del Valle, Texas 78617

TITLE:	5' X 5' JUNCTION BOX
FILE NAME:	JUNCTION BOX/5 X 5.DWG
DRAWN BY:	SUSAN MENTA
DATE:	SEPTEMBER 03, 2009