

3' X 3' JUNCTION BOX

NOT TO SCALE: ALL DIMENSIONS ARE SUBJECT TO ALLOWABLE SPECIFICATION TOLERANCES

MATERIALS & FEATURES

CONCRETE: 5,000 PSI, 28 DAY STRENGTH.
 REINFORCING: #4 BAR, GRADE 60, 8" O.C.E.W.
 #4 BAR DIAGONAL AROUND KNOCK-OUTS
 2 MATS #4 BAR 8" O.C.E.W. IN LID W/
 DIAGONAL AROUND HOLE
 STOCK DEPTH: 36"
 TOP SLAB LOAD RATING = H-20.
 EXCEEDS ASTM C858

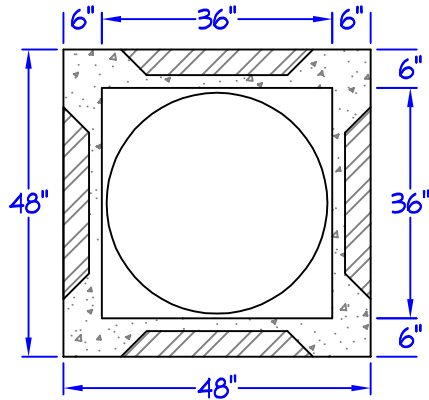

TOP VIEW

CAST IRON MANHOLE RING AND COVER AS REQUIRED (FLUSH MOUNT AVAILABLE)

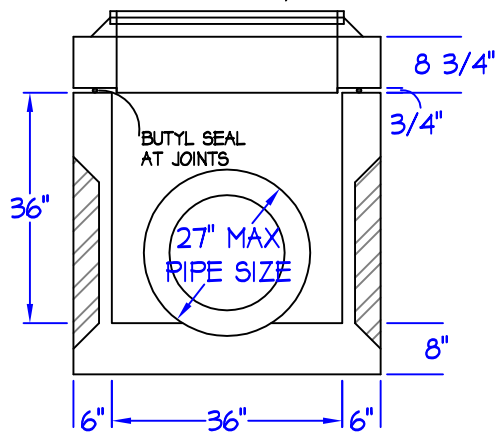

SIDE VIEW



Capital Concrete Products

5264 Hwy. 71 East • Del Valle, Texas 78617

TITLE:	3' X 3' JUNCTION BOX
FILE NAME:	JUNCTION BOX/3 X 3.DWG
DRAWN BY:	SUSAN MENTA
DATE:	SEPTEMBER 03, 2009