

60 x 60 GRATED INLET

NOT TO SCALE: ALL DIMENSIONS ARE SUBJECT TO ALLOWABLE SPECIFICATION TOLERANCES

MATERIALS & FEATURES

CONCRETE: 5,000 PSI, 28 DAY STRENGTH.

REINFORCING: #4 BAR, GRADE 60, 8" O.C.E.W.

#4 BAR DIAGONAL AROUND KNOCK-OUTS

STOCK DEPTH: 60"

TOP SLAB LOAD RATING = H-20.

EXCEEDS ASTM C858

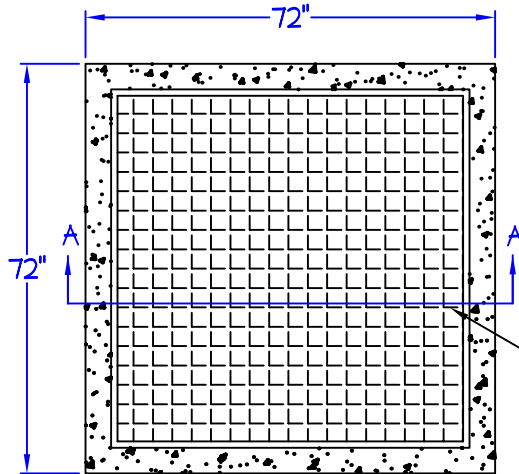

60" X 60" HEAVY DUTY GALVANIZED GRATE (TRAFFIC RATED)

TOP VIEW

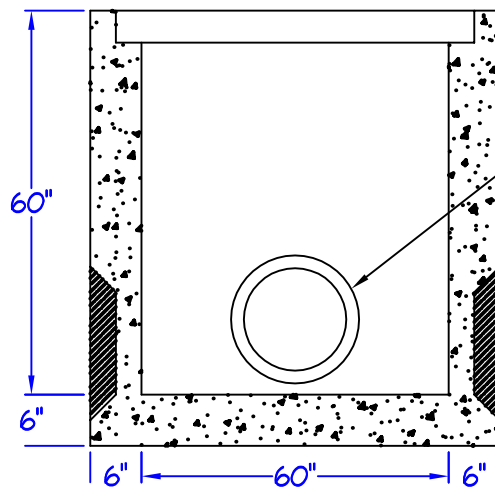

42" ϕ THIN-WALLED KNOCKOUTS
TYPICAL 2 SIDES
MAXIMUM PIPE SIZE: 36" RCP

48" ϕ THIN-WALLED KNOCKOUTS
TYPICAL 2 SIDES

SECTION A-A



Capital Concrete Products

5264 Hwy. 71 East • Del Valle, Texas 78617

TITLE:	60x60 GRATED INLET
FILE NAME:	INLETS/GRATED INLETS/60x60 GRATED INLET.DWG
DRAWN BY:	SUSAN MENTA
DATE:	SEPTEMBER 04, 2009