

48 x 48 GRATED INLET

NOT TO SCALE: ALL DIMENSIONS ARE
SUBJECT TO ALLOWABLE SPECIFICATION
TOLERANCES

MATERIALS & FEATURES

CONCRETE: 5,000 PSI, 28 DAY STRENGTH.

REINFORCING: #4 BAR, GRADE 60, 8" O.C.E.W.

#4 BAR DIAGONAL AROUND KNOCK-OUTS

STOCK DEPTH: 48"

TOP SLAB LOAD RATING = H-20.

EXCEEDS ASTM C858

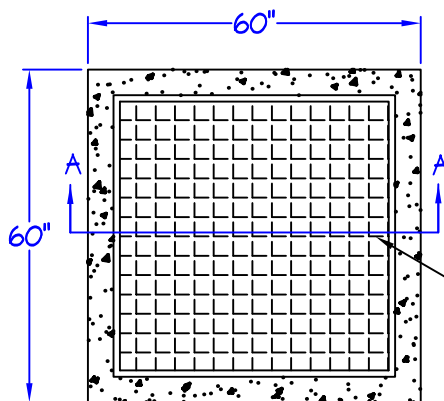

48" X 48" HEAVY DUTY GALVANIZED
GRATE (TRAFFIC RATED)

TOP VIEW

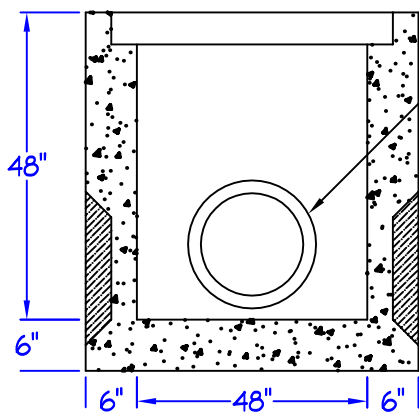

42"φ THIN-WALLED KNOCKOUTS
TYPICAL 2 SIDES

MAXIMUM PIPE SIZE: 36" RCP

48"φ THIN-WALLED KNOCKOUTS
TYPICAL 2 SIDES

SECTION A-A



Capital Concrete Products

5264 Hwy. 71 East • Del Valle, Texas 78617

TITLE:	48x48 GRATED INLET
FILE NAME:	INLETS/GRATED INLETS/48x48 GRATED INLET.DWG
DRAWN BY:	SUSAN MENTA
DATE:	SEPTEMBER 03, 2009