

# 36 x 36 GRATED INLET

NOT TO SCALE: ALL DIMENSIONS ARE SUBJECT TO ALLOWABLE SPECIFICATION TOLERANCES

**MATERIALS & FEATURES**

CONCRETE: 5,000 PSI, 28 DAY STRENGTH.

REINFORCING: #4 BAR, GRADE 60, 8" O.C.E.W.

#4 BAR DIAGONAL AROUND KNOCK-OUTS

STOCK DEPTH: 36 INCHES

42 INCHES

48 INCHES

TOP SLAB LOAD RATING = H-20.

EXCEEDS ASTM C858

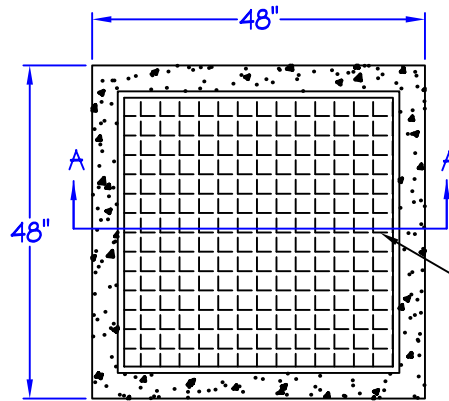

36" X 36" HEAVY DUTY GALVANIZED GRATE (TRAFFIC RATED)

TOP VIEW

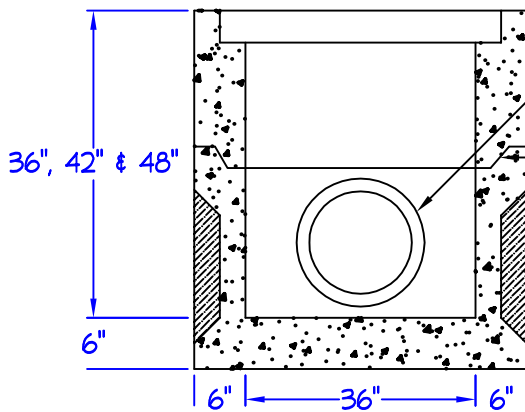

MAXIMUM PIPE SIZE: 27" RCP

TONGUE & GROOVE JOINTS FOR EXCESSIVE DEPTH INLETS CAST IN MULTIPLE SECTIONS

32"Ø THIN-WALLED KNOCKOUTS TYPICAL 4 SIDES

SECTION A-A



**Capital Concrete Products**

5264 Hwy. 71 East • Del Valle, Texas 78617

TITLE:	36x36 GRATED INLET
FILE NAME:	INLETS/GRATED INLETS/36x36 GRATED INLET.DWG
DRAWN BY:	SUSAN MENTA
DATE:	SEPTEMBER 03, 2009