

24 x 24 GRATED INLET

NOT TO SCALE: ALL DIMENSIONS ARE SUBJECT TO ALLOWABLE SPECIFICATION TOLERANCES

MATERIALS & FEATURES
 CONCRETE: 5,000 PSI, 28 DAY STRENGTH.
 REINFORCING: #4 BAR, GRADE 60, 6" O.C.E.W.
 #4 BAR DIAGONAL AROUND KNOCK-OUTS
 STOCK DEPTH: 24 INCHES
 36 INCHES
 48 INCHES
 TOP SLAB LOAD RATING = H-20.
 EXCEEDS ASTM C858

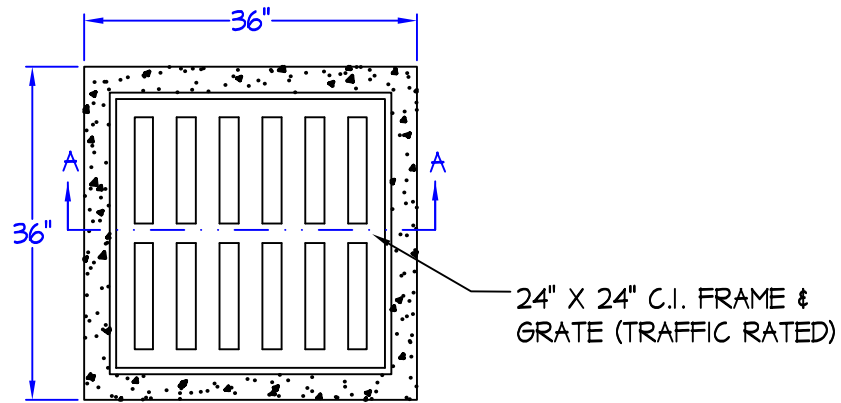

TOP VIEW

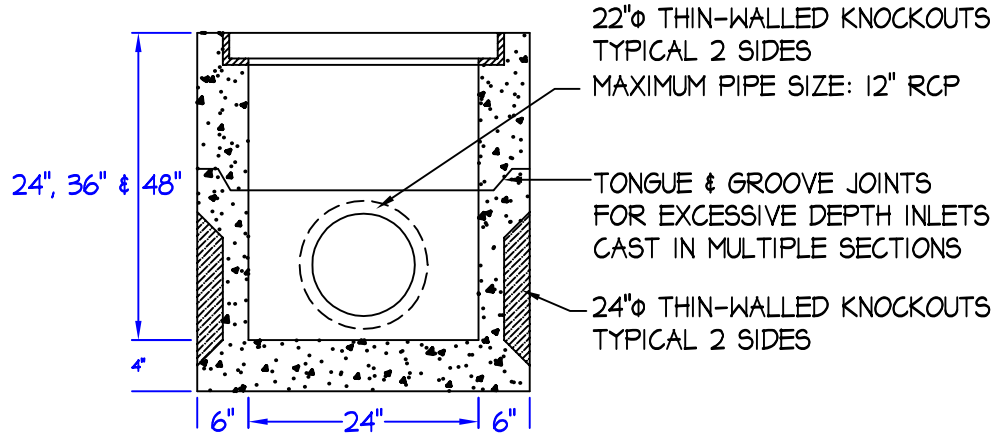

SECTION A-A



Capital Concrete Products
 5264 Hwy. 71 East • Del Valle, Texas 78617

TITLE:	24x24 GRATED INLET
FILE NAME:	INLETS/GRATED INLETS/24x24 GRATED INLET.DWG
DRAWN BY:	SUSAN MENTA
DATE:	SEPTEMBER 03, 2009