

4' X 4' AREA INLET

NOT TO SCALE: ALL DIMENSIONS ARE SUBJECT TO ALLOWABLE SPECIFICATION TOLERANCES

MATERIALS & FEATURES

CONCRETE: 5,000 PSI, 28 DAY STRENGTH.
 REINFORCING: #4 BAR, GRADE 60, 8" O.C.E.W.
 #4 BAR DIAGONAL AROUND KNOCK-OUTS
 2 MATS #4 BAR 8" O.C.E.W. IN LID W/
 DIAGONAL AROUND HOLE
 STOCK DEPTH: 48"
 TOP SLAB LOAD RATING = H-20.
 EXCEEDS ASTM C858

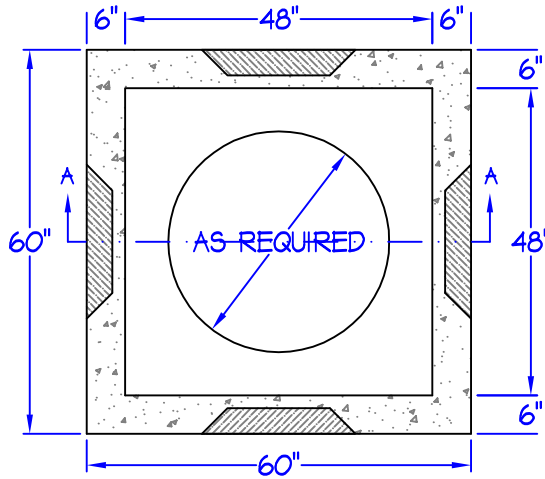

TOP VIEW

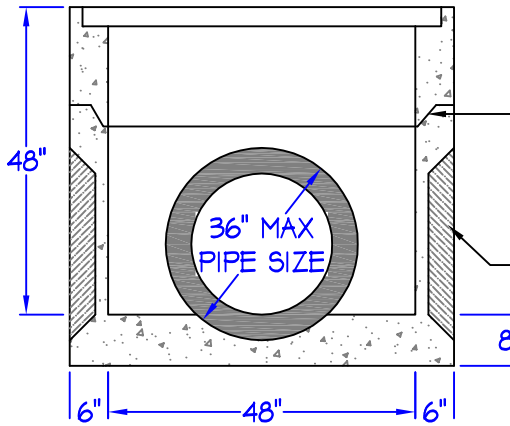
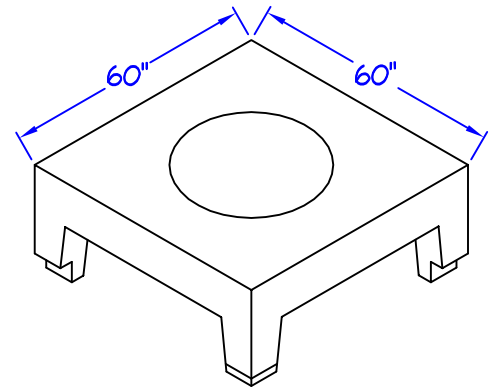
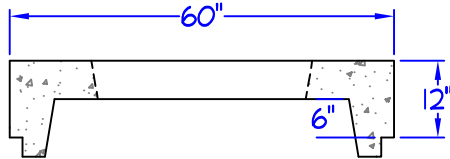

SECTION AA

TONGUE & GROOVE JOINTS FOR EXCESSIVE DEPTH INLETS CAST IN MULTIPLE SECTIONS

THIN-WALLED KNOCKOUTS TYPICAL 4 SIDES

