

# 3' x 3' AREA INLET

NOT TO SCALE: ALL DIMENSIONS ARE SUBJECT TO ALLOWABLE SPECIFICATION TOLERANCES

**MATERIALS & FEATURES**  
 CONCRETE: 5,000 PSI, 28 DAY STRENGTH.  
 REINFORCING: #4 BAR, GRADE 60, 8" O.C.E.W.  
 #4 BAR DIAGONAL AROUND KNOCK-OUTS  
 STOCK DEPTH: 36 INCHES  
 42 INCHES  
 48 INCHES  
 TOP SLAB LOAD RATING = H-20.  
 EXCEEDS ASTM C858

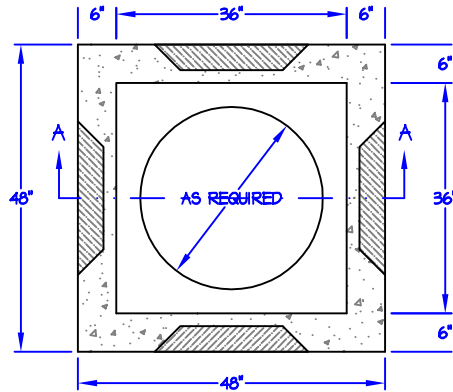

TOP VIEW

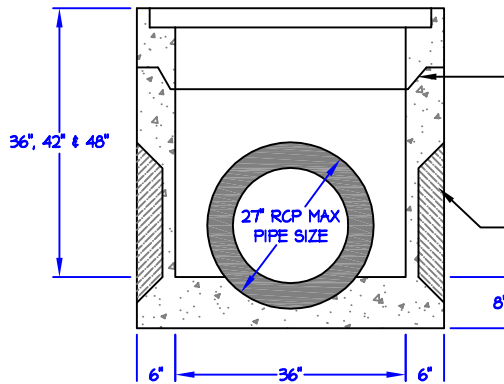
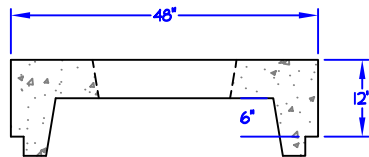
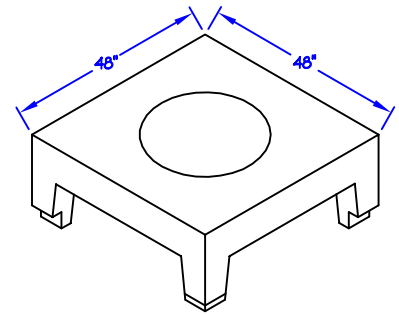

TONGUE & GROOVE JOINTS FOR EXCESSIVE DEPTH INLETS CAST IN MULTIPLE SECTIONS

THIN-WALLED KNOCKOUTS TYPICAL 4 SIDES

SECTION AA



**Capital Concrete Products**

5264 Hwy. 71 East • Del Valle, Texas 78617

TITLE:	3x3' AREA INLET
FILE NAME:	INLETS/AREA INLETS/36x36 AREA INLET.DWG
DRAWN BY:	SUSAN MENTA
DATE:	SEPTEMBER 11, 2009