

48" PULLBOX-NON TRAFFIC TYPE - AUSTIN

NOT TO SCALE: ALL DIMENSIONS ARE SUBJECT TO ALLOWABLE SPECIFICATION TOLERANCES

MATERIALS & FEATURES
 CONCRETE: CLASS "A", 5,000 PSI.
 48" PULLBOX WEIGHT: 4,915 LBS.

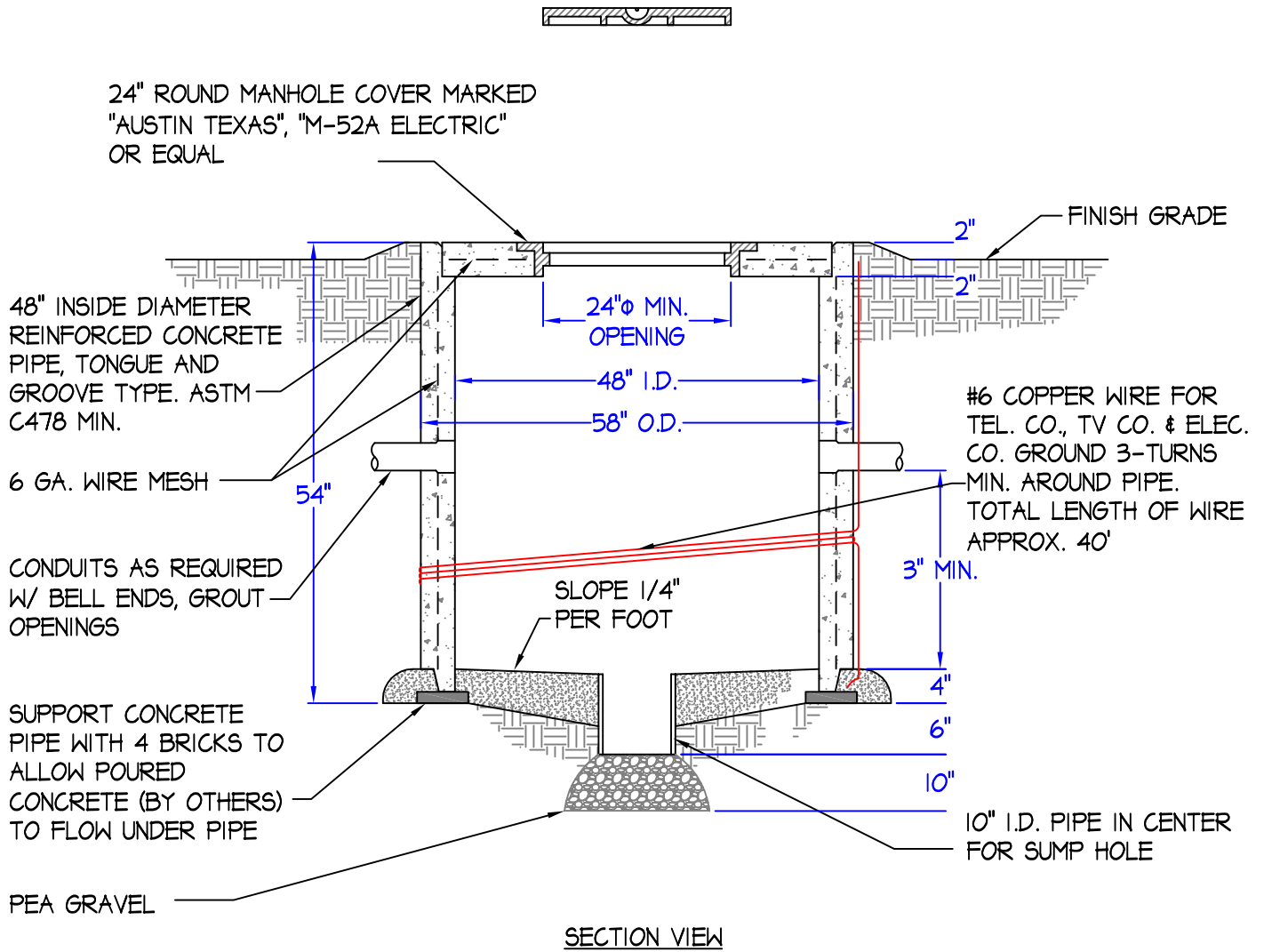

CAPITAL CONCRETE PRODUCTS, INC.
 5264 HIGHWAY 71 EAST
 DEL VALLE, TEXAS 78617
 PHN: (512) 247-4193
 FAX: (512) 247-4163

TITLE:	48" PULLBOX-NON TRAFFIC TYPE -AUSTIN
FILE NAME:	CAPITAL CONCRETE/48 PULLBOX NON.DWG
DRAWN BY:	SUSAN MENTA
DATE:	DECEMBER 05, 2008