

# 48" I.D. PRECAST MANHOLE - 6" EXTENDED BASE WITH INVERT CHANNEL

NOT TO SCALE: ALL DIMENSIONS ARE SUBJECT TO ALLOWABLE SPECIFICATION TOLERANCES

**MATERIALS & FEATURES**  
 CONCRETE: 4,000 PSI, 28 DAY STRENGTH.  
 AVERAGE WEIGHT OF 26" DEPTH BASE W/ 8" INVERT = 5,100 LBS EXCEEDS ASTM C-478-03A  
 WATER-TIGHT NPC GASKETS AT ALL PIPE CONNECTIONS  
 HOLES AS SPECIFIED - MAX. 32"  $\phi$

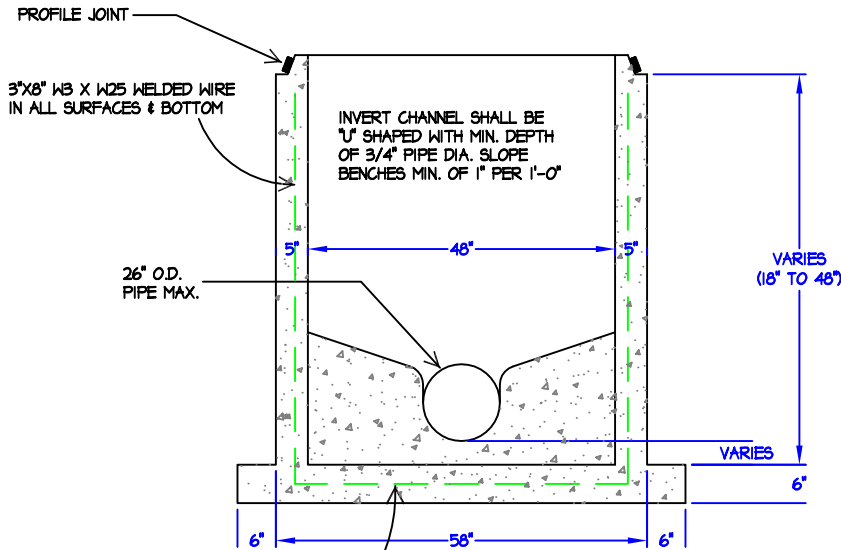

FOR PIPE ENTERING THE MANHOLE AT EXCESSIVE DEPTHS ABOVE THE FLOW LINE OUT, THE CONTRACTOR MAY BE RESPONSIBLE FOR GROUT WORK NECESSARY TO BRING CHANNEL UP TO FLOW LINE ON INLET PIPE.

CONTRACTOR RESPONSIBLE FOR ADDITIONAL FILLER AROUND PIPE AFTER INSTALLATION.

GROUTED INVERT W/OFFSET TO MATCH FLOWLINE OF PIPE SLIGHT FIELD MODIFICATIONS MAY BE NECESSARY

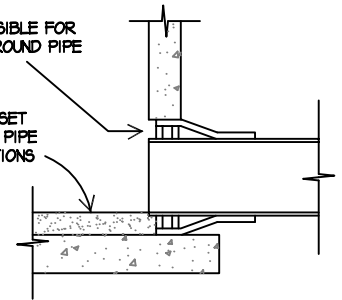

#4 BAR @ 90° CROSS IN BOTTOM & SIDES  
 #4 BAR @ 12" ON CENTER EACH WAY IN BOTTOM (CONTINUOUS AROUND OPENINGS & SIDES)

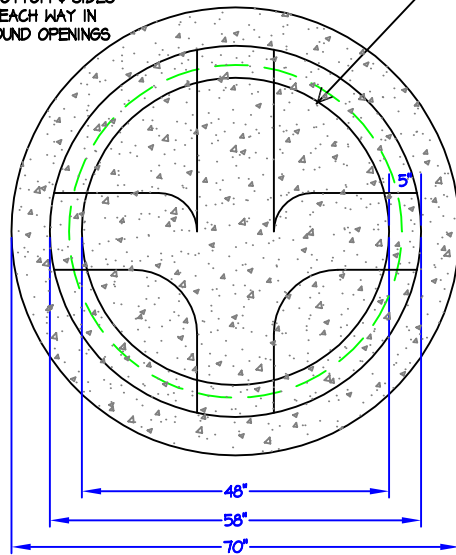

**Capital Concrete Products**

5264 Hwy. 71 East • Del Valle, Texas 78617

TITLE:	48" I.D. PRECAST EXT 6" BASE - INV. CH.
FILE LOC.:	MANHOLES/ 48 ID MANHOLES
DRAWN BY:	SUSAN MENTA
DATE:	OCTOBER 14, 2009