

# 48" I.D. MANHOLE - 12" EXTENDED BASE WITH REDUCING CONE

NOT TO SCALE: ALL DIMENSIONS ARE SUBJECT TO ALLOWABLE SPECIFICATION TOLERANCES

### MATERIALS & FEATURES

CONCRETE: 4,000 PSI, 28 DAY STRENGTH.  
 AVERAGE WEIGHT OF 26" DEPTH BASE W/ 8" INVERT = 5,100 LBS  
 ESTIMATED WEIGHT OF RISER & CONE  
 SECTIONS = 870 LBS / VERTICAL FOOT  
 EXCEEDS ASTM C-478-03A  
 WATER-TIGHT NPC GASKETS AT ALL PIPE CONNECTIONS  
 HOLES AS SPECIFIED - MAX. 32" Ø

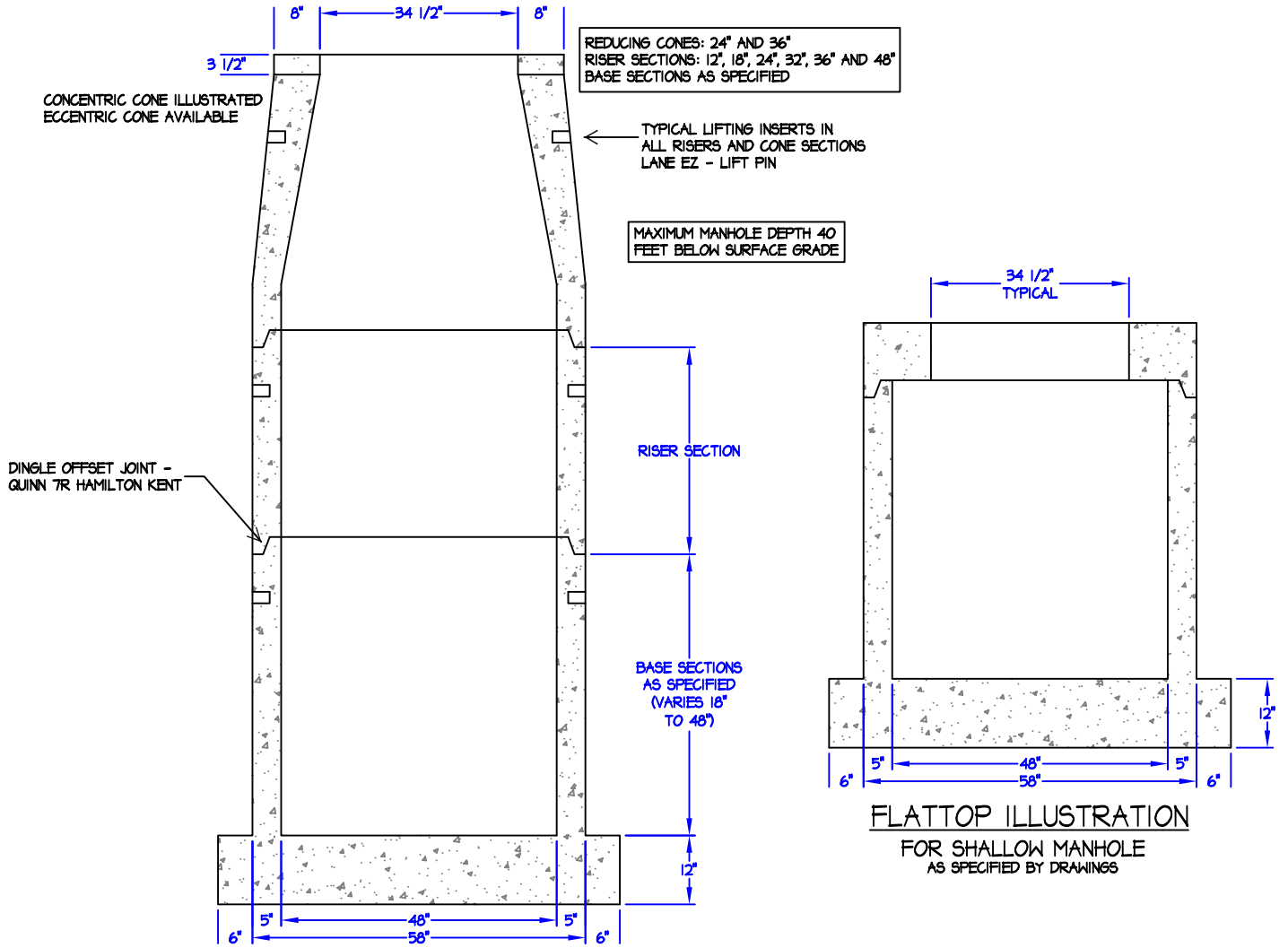

**Capital Concrete Products**

5264 Hwy. 71 East • Del Valle, Texas 78617

TITLE:	48" I.D. MANHOLE EXT 12" BASE - NO CH. & CONE
FILE LOC.:	MANHOLES/ 48 ID MANHOLES
DRAWN BY:	SUSAN MENTA
DATE:	OCTOBER 14, 2009